

CAUTION . READ THESE INSTRUCTIONS BEFORE USING THIS MACHINE

TORNADO INDUSTRIES, LLC
333 CHARLES COURT
WEST CHICAGO, IL 60185
(630)-818-1300 FAX (630)-818-1301
WWW.TORNADOVAC.COM



Operations & Maintenance Manual
For Commercial Use Only

**BD 26/27 RIDE ON SCRUBBER
MODEL NO: 99770**



SUMMARY	1	Working in manual mode	12
LEGEND PANEL OF CONTROLS	4	Working adjustments	12
LEGEND MACHINE	4	Flow adjustment of the detergent solution	12
TECHNICAL DESCRIPTION	5	Brush pressure adjustment	12
INTRODUCTION	6	Electric protection	13
GENERAL RULES OF SECURITY	6	Overflow device	13
SYMBOLS	6	STOPPING THE MACHINE AFTER CLEANING	13
BEFORE USE	7	DAILY MAINTENANCE	13
Handling packed machine	7	Emptying and cleaning the recovery tank	13
Unpacking the machine	7	Cleaning the vacuum filter	14
Access to the battery compartment	7	Cleaning the brushes	14
Battery installation	7	Disassembling the brushes	14
Battery charger	7	Cleaning the squeegee	14
Battery charging	8	WEEKLY MAINTENANCE	14
Batteries disposal	8	Rear squeegee rubber check	14
Connecting the batteries' connector and switching on the machine	8	Squeegee hose cleaning	14
Battery charge level indicator	8	Cleaning the solution tank and the outer filter	14
Setting the battery check card	8	TWO-MONTHLY MAINTENANCE	15
Hour meter	9	Front squeegee rubber check	15
Squeegee assembly	9	SIX-MONTHLY MAINTENANCE	15
Squeegee adjustment	9	Splash guard rubber check	15
Splash guard assembly	9	Cleaning the inner filter OF THE solution tank	15
assembling the brushes	10	Checking the brakes	15
FLOOR CLEANING	10	TROUBLESHOOTING GUIDE	15
Recovery tank	10	The VACUUM motor does not work	15
Detergent solution tank	10	The brush motor does not work	15
STARTING THE MACHINE	10	The traction motor does not work	15
Forward and backward movement	11	The water does not come down onto the brushes or is insufficient	16
Horn	11	The machine does not clean properly	16
Working brake	11	The squeegee does not dry sufficiently	16
Emergency brake	11	Excessive foam production	16
Automatic squeegee lifting when going backwards	11	PROGRAMMED MAINTENANCE	17
Working in automatic mode	11	RECOMMENDED BRUSHES	17

LEGEND PANEL OF CONTROLS

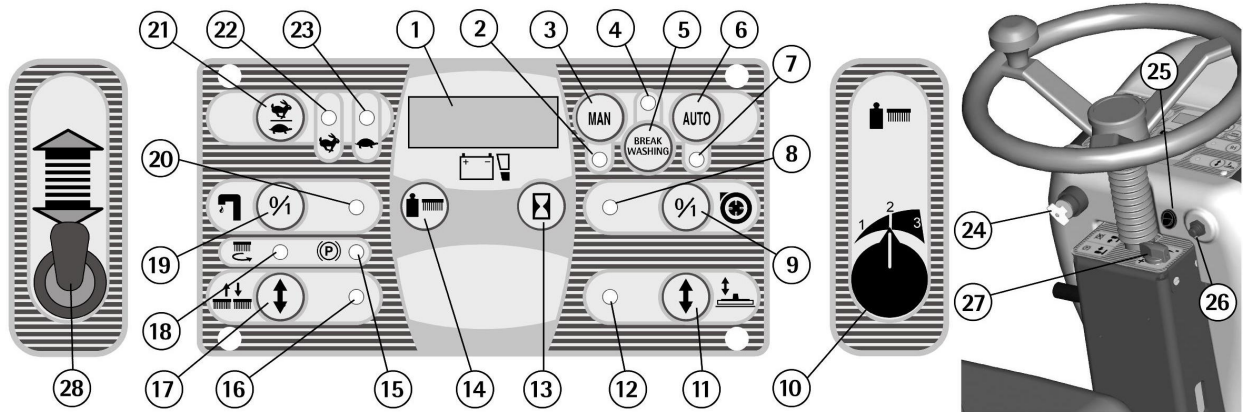

- | | |
|--|---|
| 1. Display | 15. Signal Lamp For Parking Brake On |
| 2. Signal Lamp Manual Mode On | 16. Signal Lamp Brushes Raise/Lower |
| 3. Push Button For Manual Mode | 17. Push Button Raise/Lower Brushes |
| 4. Signal Lamp Mode Break Washing On | 18. Signal Lamp Starting Brushes Rotation |
| 5. Push Button For Break Washing Mode | 19. Switch Water Opening (Solenoid Valve) |
| 6. Push Button For Automatic Mode | 20. Signal Lamp Water Open (Solenoid Valve) |
| 7. Signal Lamp Automatic Mode On | 21. Push Button For Speed Selection |
| 8. Signal Lamp Vacuum Motor On | 22. Signal Lamp Fast Speed |
| 9. Switch For Vacuum Motor | 23. Signal Lamp Slow Speed |
| 10. Adjustment Knob For Brush Pressure | 24. Key Switch |
| 11. Push Button To Raise/Lower Squeegee | 25. Switch For Front Light (Optional) |
| 12. Signal Lamp Squeegee Raise/Lower | 26. Push Button For Horn |
| 13. Push Button Visualization Hour Meter (Display) | 27. Knob For Solution Valve |
| 14. Push Button Visualization Brushes Pressure Set (Display) | 28. Direction Of Drive Selector |

LEGEND MACHINE

- | | |
|-----------------------------------|---------------------------------------|
| 1. Recovery Tank | 12. Squeegee Assembly |
| 2. Solution Tank | 13. Panel Controls |
| 3. Seat | 14. Lever Block/Release Parking Brake |
| 4. Steering Wheel | 15. Cover Electrical Layout |
| 5. Screw Cap For Solution Tank | 16. Brake Pedal |
| 6. Vacuum Hose | 17. Accelerator Pedal |
| 7. Vacuum Cover | 18. Outer Filter Detergent Solution |
| 8. Blocking Levers Vacuum Cover | 19. Drive Wheel |
| 9. Squeegee Hose | 20. Bottom Plate |
| 10. Recovery Tank Drain Hose Plug | 21. Brushes Base Group |
| 11. Recovery Tank Drain Hose | 22. Traction Wheels |

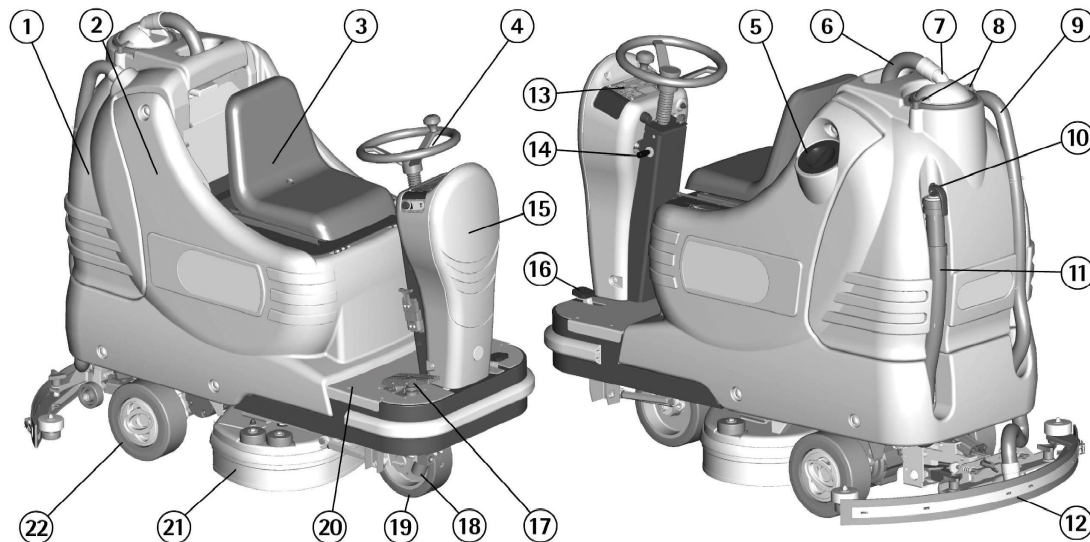

TECHNICAL DESCRIPTION	U/M	BD26/27
Cleaning width	in	26
Squeegee width	in	38.5
Working capacity, up to	sqm/h	35,521
Brush diameter	in	2 x 13.5
Brush speed	rpm	190
Brush pressure	lb	133
Brush motor	W	650 (27 A)
Traction motor	W	500 (25 A)
Vacuum motor	W	580 (24 A)
Suction vacuum	Water lift	64+
Type of drive		Auto
Movement speed	Mph	0 to 3.1
Maximum gradient	%	10
Solution tank capacity	Gallon	26.4
Recovery tank capacity	Gallon	27.7
Machine length	In	62
Machine height	In	52
Machine width (without squeegee)	in	28
Weight of the machine (empty and without batteries)	lb	573
Battery compartment	in	16 x 20 x 15
Sound pressure level (in conformity with EN 60704-1)	dB (A)	<70
Class		III
Protection level	IPX	3
Voltage	V	24

INTRODUCTION

Thank you for choosing our machine. This floor cleaning machine is used for industrial and commercial cleaning and is able to clean any type of floor. While moving forward, the combined action of the brushes and the detergent solution removes the dirt which is picked up through the rear vacuum assembly, leaving a dry surface.

This machine must only be used for the manufacturer's approved application. It gives the best performance if it is used correctly and maintained properly. We therefore ask you to read this instruction manual carefully. Please contact our service department for advice and when service is required.

GENERAL RULES OF SECURITY

The rules below must be followed carefully in order to avoid injury and damage to the machine.

- Read the labels carefully on the machine. Do not cover them for any reason and replace them immediately if damaged.
 - This machine must be used only by authorized staff that has been properly trained.
 - Keep children and unauthorised persons away from the machine when in use.
 - In case of danger act immediately upon the emergency brake.
 - When the machine is parked, remove the key and put the parking brake on.
 - Do not mix different detergents, to avoid harmful odours.
 - Storage temperature: between -13° and 131° F (-25° and $+55^{\circ}$ C).
 - Operating temperature: between 32° and 104° F (0° and 40° C).
 - The humidity should be between 30 and 95%.
 - Do not use the machine in an explosive atmosphere.
 - Do not use the machine as a means of transport.
 - Do not use acid solutions in such concentrations that could damage the machine and/or the persons.
 - Do not use the machine on surfaces covered with inflammable liquids or dusts (for example hydrocarbons, ashes or soot).
 - In case of fire, use a powder fire-extinguisher.
- Do not use water.

- Do not strike shelving or scaffoldings, where there is danger of falling objects.

- Adapt the machine speed to the working conditions: particularly, slow down before narrow curves have to be faced.

- Do not use the machine on areas having a higher gradient than the one stated on the plate number.

- The machine carries out simultaneous operations of washing and drying. Different operations must be carried out in restricted areas prohibited to non-authorized personnel. Signal the areas of wet floors with suitable signs.

- If the machine does not work properly, check by conducting simple maintenance procedures. Otherwise, ask for technical advice from an authorized service center.

- When parts are required, ask for ORIGINAL spare parts from a distributor or an authorized dealer.

- Use only ORIGINAL brushes.

- For cleaning and/or maintenance operations turn off the power supply from the machine.

- Do not take off the protections which require the use of tools to be removed.

- Do not wash the machine with direct water jets or with high water pressure nor with corrosive material.

- Every 200 working hours have the machine checked by an authorized service agent.

- In order to avoid scales on the solution tank filter, do not fill the machine with cleaning solution many hours before use.

- Before using the machine, check that all panels and coverings are in position as indicated in this manual.

- Restore all electrical connections after any maintenance operation.

- Provide for the scrapping of the material of normal wear following strictly the respective rules.

- When the machine can no longer be used, provide for the appropriate waste disposal of its materials, especially oils, batteries and electronic components.

SYMBOLS



Indicates the solution valve lever



Indicates the solution valve that adjusts the flow of solution detergent.



Indicates the maximum temperature of the solution detergent.



Indicates the machine is in manual mode.



Indicates the machine is in automatic mode.



Indicates the machine is in break washing mode.



Indicates the switch of the brush motor.

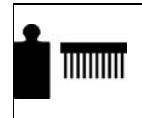

Indicates the push button to show the brush pressure set on the display.

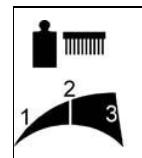

Indicates the button to adjust the brush pressure.

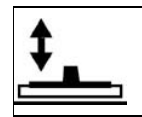

Indicates the squeegee lever



Indicates the switch of the vacuum motor



Indicates the battery charge level.



Indicates the hour meter.

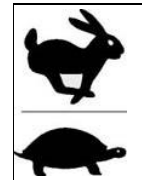

Indicates the switch for driving speed.

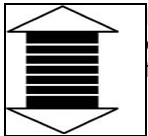

Indicates the direction of operation: forwards/backwards.



Indicates the brake. Light indicates the brake is on.

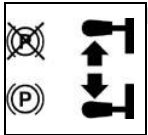

Indicates the parking brake.



Indicates the operator has to read the manual before using the machine.



Warning symbol. Read carefully the sections marked with this symbol.

BEFORE USE

HANDLING PACKED MACHINE

The machine is supplied with suitable packing for fork lift handling.
Total weight: 290kg.
Packing dimensions:
Base: 178 cm x 93 cm
Height: 138 cm



ATTENTION:

Do not place more than two packages on top of each other.

UNPACKING THE MACHINE

1. Remove the external packing.
2. Unscrew the brackets (1 and 2) that secure the machine to the pallet.

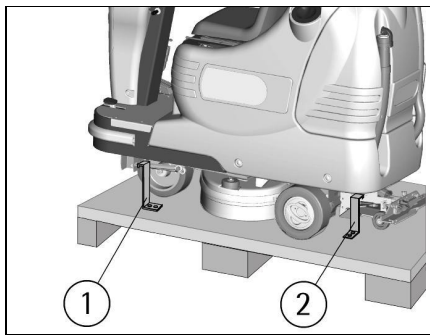

3. Move the machine backwards, as indicated in the figure, avoiding heavy contact to any mechanical parts.

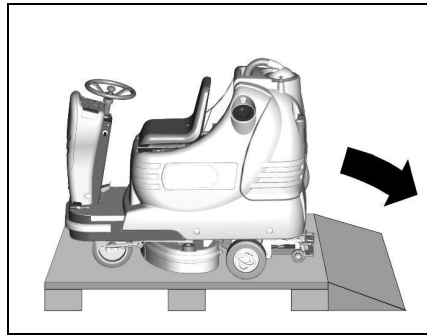

4. Keep the pallet and the brackets for future transport.

ACCESS TO THE BATTERY COMPARTMENT

1. Ensure the machine is on a flat surface.
 2. Rotate the seat platform forward and hook the bar.
- When the operation is finished close the battery compartment and reposition the seat platform.

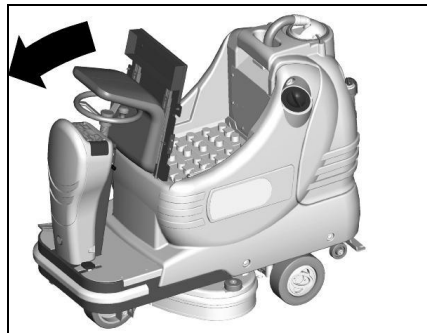

To install a battery into the compartment, it is necessary to:

1. Rotate the seat platform forward and hook the bar (2) into position A.
2. Remove the holder (1) by unscrewing the two wing nuts under the platform.
3. Pull the releasing lever of the seat outwards (3) sliding the seat (4) up to the highest position.
4. Rotate the platform further in order to hook the bar (2) into position B. This position will allow batteries to be handled using suitable lifting equipment.

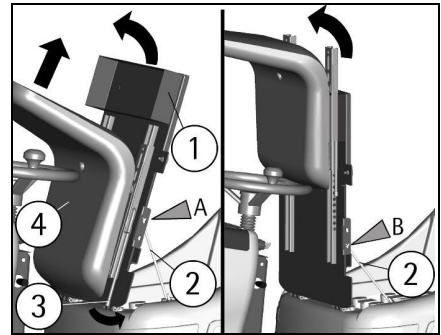

BATTERY INSTALLATION

The machine is equipped batteries connected in series for a total of 24 Volts, placed in its appropriate compartment under the seat platform and must be handled using suitable lifting equipment (due to weight, considering the type of batteries, and coupling system).



ATTENTION:

The machine and the battery check card indicates the use of traditional lead batteries.
CHECK THE SETTING OF THE CHECK CARD on the indicator (see under paragraph "BATTERY CHARGE LEVEL INDICATOR").
If using GEL batteries it is necessary to **MODIFY THE SETTING** of the electronic check card (see under paragraph **SETTING THE BATTERY CHECK CARD**).



ATTENTION:

Strictly follow manufacturer/distributor indications for the maintenance and recharging of batteries. All installation and maintenance operations must be carried out by authorized staff, using suitable protection accessories.

To install the batteries it is necessary to reach the battery compartment as indicated under paragraph **ACCESS TO THE BATTERY COMPARTMENT**.

1. Place the batteries in the compartment.
2. Connect the terminals. Pay attention to the polarities and avoid contact with other parts that could short circuit.

BATTERY CHARGER

Be sure that the battery charger is suitable for the batteries installed (lead/acid or GEL or equivalent).

BATTERY CHARGING

1. Plug the battery connector (3) of the battery charger into the battery connector (1).
2. Proceed with charging.

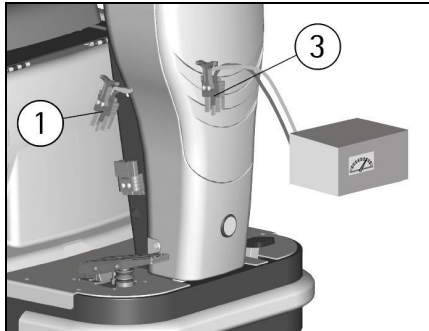

ATTENTION:

Never charge a GEL battery with a non suitable charger. Strictly follow the instructions supplied by the battery and charger manufacturer. In order not to cause permanent damage to the battery, avoid complete discharge. Charge the battery within a few minutes after the battery discharge signal starts blinking. NOTE: Never leave the battery completely discharged even when the machine is not in use. In case of traditional batteries, please check the electrolyte level every 20 charging cycles and top them up with distilled water. Never leave the batteries discharged for more than two weeks.



ATTENTION:

When charging the battery it is important to follow all instructions given by the manufacturer or distributor. Installation and maintenance operations must be carried out by qualified staff. Danger of gas exhalations and emission of corrosive liquids. Fire danger: do not approach with free flames.

BATTERIES DISPOSAL

It is mandatory to hand over exhausted batteries, classified as dangerous waste, to an authorized institution according to the current laws.

CONNECTING THE BATTERIES CONNECTOR AND SWITCHING ON THE MACHINE

Once the battery has been charged:

1. Disconnect the connector of the battery charger from the battery connector (1).
2. Reconnect the battery connector to the machine connector (2).

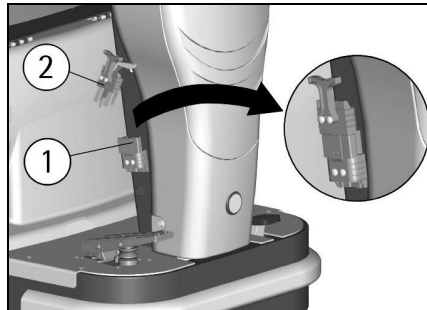

BATTERY CHARGE LEVEL INDICATOR

To start any function of the machine, it is necessary to rotate the key clockwise (24). Rotating it counter clockwise will switch the machine off.

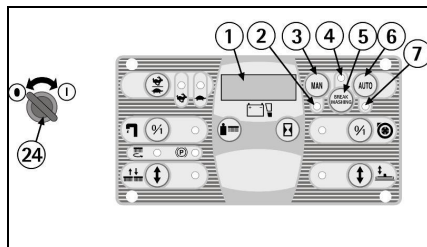

When the machine is switched on, information will be displayed in the following order (1):

1. the version (for example A003) of software installed on the machine.

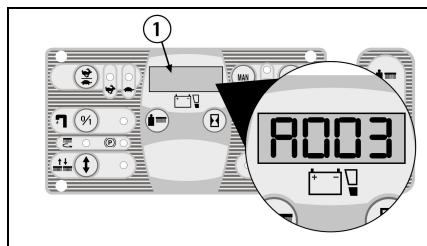

2. the setting of the battery check card which can be:
GE 24 (check card set for GEL batteries).
or
Pb 24 (check card set for lead batteries).

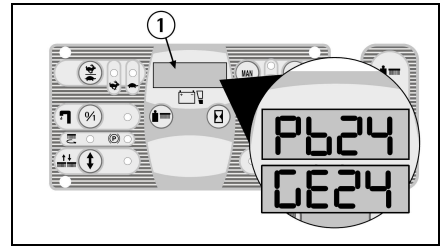

3. The battery charge level indicator is digital and remains fixed on the display. The battery charge level starts from 100, which indicates 100% of the total charge and decreases in 10% to 10. When the charge level reaches 20%, the display starts blinking.

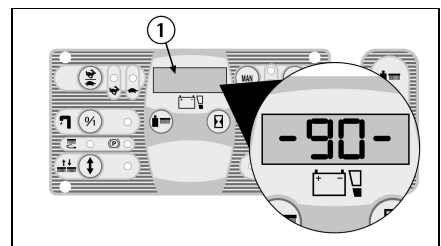

ATTENTION:

After a few seconds when the four lines start blinking, all the functions stop automatically. With the remaining charge it is possible to finish the drying operation before proceeding to charge.

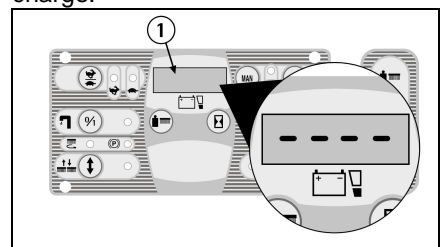

SETTING THE BATTERY CHECK CARD

The machine, if not specified otherwise, is supplied with the battery check card set for lead batteries. To modify this setting, it is necessary to:

1. Switch the machine off then back on.
2. Immediately after having switched the machine back on, when the writing Pb24 appears on the display (1), press simultaneously the buttons (3) and (6) until the writing begins to flash.
3. When the writing begins to flash, release the buttons and press the button again once (6).

4. The writing GE24 appears flashing.
5. When the writing stops flashing, the setting is modified.

To change the setting from gel batteries to lead batteries, repeat the procedure pressing button (3) instead of button (6).

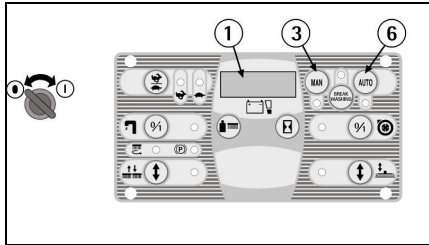

HOUR METER

The machine is equipped with an hour meter located on the same display (1) as the battery charge level indicator. Hold the button (13), the first data indicates the working hours and after a few seconds the working minutes are shown.

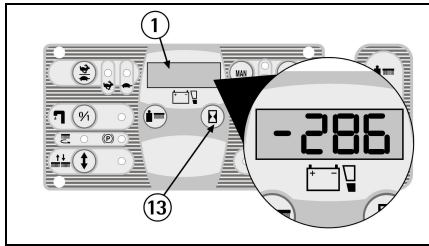

SQUEEGEE ASSEMBLY

1. Keep the squeegee support (1) slightly lifted from the floor.
2. Insert the threaded parts of the two bolts (4) sliding them inside the two slots on the support placed on the upper part of the squeegee (2).
3. Put the washers (3) into position, there are two for each bolt, so that they are assembled one under and the other over each of the two slots present on the support.
4. Secure the squeegee by rotating the two levers (4) clockwise.
5. Insert the squeegee hose (5) into its coupling, follow the picture for positioning.

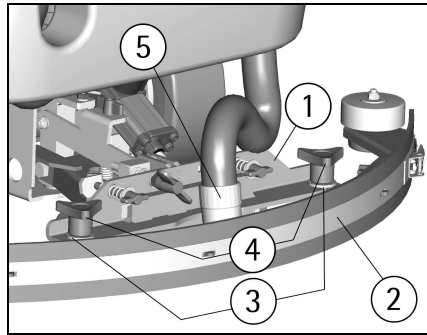

SQUEEGEE ADJUSTMENT

In order to achieve good drying results, the rear rubber of the squeegee must be bent equally in length. To adjust, it is necessary to put the machine in operation and therefore the vacuum motor has to be switched on and the brushes have to function together with the detergent solution.

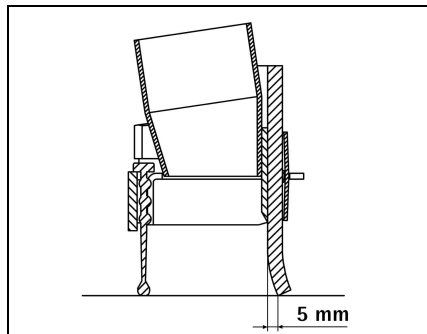

The lower part of the rubber is overly bent

Take off the pressure by rotating the wing nut (6) counterclockwise.

The lower part of the rubber is not bent enough

Increase the pressure rotating the wing nut (6) clockwise. Check that the wheels that adjust the height are not resting on the floor, in this case adjust them as indicated in paragraph "Height adjustment".

The bend is not equal

Adjust the squeegee inclination rotating the wing nut counterclockwise (7) to increase the bend in the central part, or clockwise to increase the bend on the outer part.

Height adjustment

Once the pressure and inclination of the squeegee have been adjusted, it is necessary to fix this optimum condition ensuring the wheels only slightly touch the floor. Rotate counterclockwise the bolts (8) to lower the wheels or clockwise to raise them.

Both wheels must be adjusted to the same height.

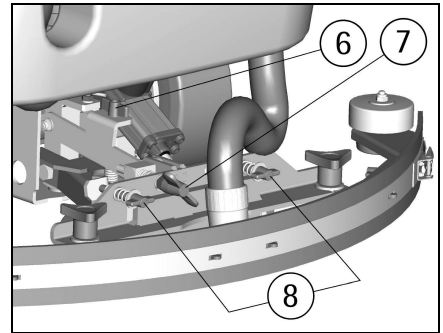

ATTENTION:

Every type of floor requires a specific adjustment. For example, concrete floors (where the friction results will be high) need little pressure, while smooth floors (ceramics) need higher pressure. If the cleaning operations are made always on the same type of floor, the adjustment can change only in function of the rubber wear.

SPLASH GUARD ASSEMBLY

The two splash guards have to be assembled onto the brushes base group as indicated in the following figures. Insert the metal strips inside the slots present on the rubber. Place the round hole at the extremity of the strip onto the screw (1) place in the front part of the brushes base group. Secure the strips through the nut blocking it.

Secure the coupling lever (2) in the rear part of the brushes base group to the ring placed at the extremity of the metal strip still free. Repeat as above for both splash guard rubbers.

The splash guard must slightly touch the floor when the brushes are assembled.

To remove the splash guard follow the above instructions in reverse.

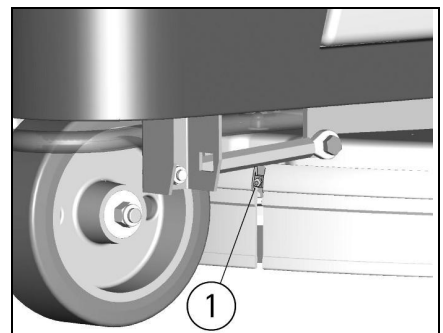

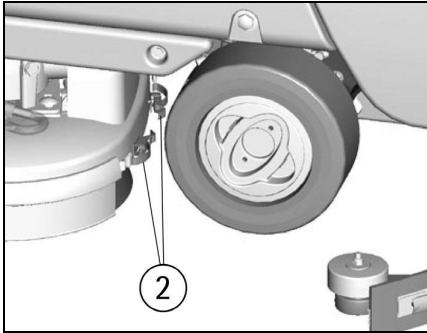

ASSEMBLING THE BRUSHES

To assemble the brushes it is necessary that the brushes base is in the lifted position. If it is not lifted, proceed as follows:

Without the operator seated, turn the key switch clockwise, the display comes on and after 3 seconds all working groups switch off automatically and are lifted from the floor.

Switch off the machine turning the key counterclockwise.



ATTENTION:

Carrying out brush operations with the electric supply on may cause injury.

With the base of the brushes in the lifted position, insert the brushes into their plate seat underneath the brushes base turning them until the three metal buttons are properly seated in their slots; rotate the brushes to push the button towards the coupling spring until they are locked.

The figure shows the rotating direction for brushes coupling.

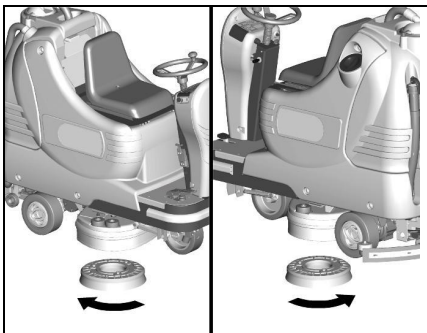

For a longer life of the brushes we suggest to daily alternate their position. Whenever brushes do become deformed we suggest to reassemble them in the same position, in order to avoid that the different

inclination of the bristles causes excessive motor overload or troublesome vibrations.

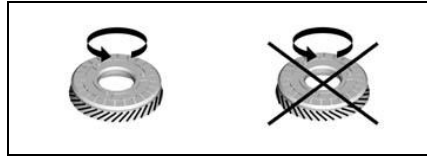

ATTENTION:

Use only brushes supplied with the machine or ones indicated in the paragraph **RECOMMENDED BRUSHES+**. The use of other brushes can affect the cleaning result.

FLOOR CLEANING

RECOVERY TANK

Check that the cover of the vacuum filter (1) is correctly secured, after rotating the levers (2) and that the vacuum motor hose (3) is correctly connected to it.

Verify also that the squeegee hose couplings (4/5) are correctly inserted into their seats and that the drain hose plug (6) placed in the rear part of the machine is closed securely.

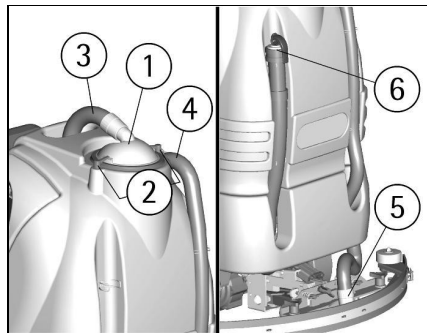

DETERGENT SOLUTION TANK

The solution tank capacity is indicated in the technical data.

Open the screw cap placed in the left part of the machine and fill the solution tank with clean water at a maximum temperature of 122° F (50°C). Add the liquid detergent in the percentage and conditions recommended by the manufacturer. To avoid excessive foaming, which could cause problems to the vacuum motor, use a minimum amount of detergent. Screw down the cap to close the tank.

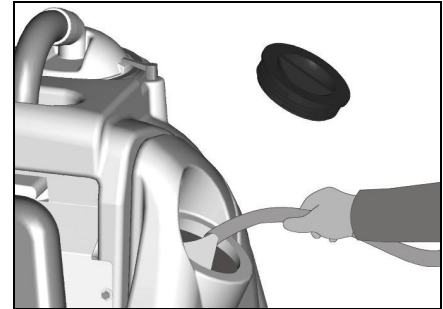

ATTENTION:

Always use a low foaming detergent. To avoid foaming, before starting the machine, use a small amount of anti-foaming product in the recovery tank. Never use pure acid.

STARTING THE MACHINE

A safety device ensures that if the operator is not seated correctly in the seating position the machine does not move.

To switch on the machine:

1. Sit on the seat.
2. Turn the key switch (24) clockwise to switch on the machine. Automatically, the machine gets ready in manual (MAN) mode and in forward movement with the quick speed (signal lamp 22).

3. Check the charge level of the batteries on the display (1).

4. Pressing the push button (5) the functioning of BREAK WASHING is chosen and the transfer operations of the machine are carried out (see under paragraph **FORWARD AND BACKWARD MOVEMENT**). When the signal lamp (4) is on the machine is in BREAK WASHING mode.

5. Pressing the push button (6) the automatic (AUTO) function is chosen, when pressing the push button (3), the function of the machine becomes manual (MAN).

A. When the signal lamp (7) is on, the machine is functioning in automatic (AUTO) mode and the machine activates and deactivates all the working functions in an automatic mode (see under paragraph **WORKING IN AUTOMATIC MODE+**).

B. When the signal lamp (2) is on, the machine is functioning in manual (MAN) mode and it is then possible to choose:

- I. to transport the machine without activating or deactivating the working functions.

II. to separately activate only the controls relative to the washing function with the brushes (see under paragraph **WORKING IN MANUAL MODE**).

III. to separately activate only the controls relative to the drying function with the squeegee (see under paragraph **WORKING IN MANUAL MODE**).



ATTENTION:

In manual mode every function of the machine has to be activated or deactivated manually.

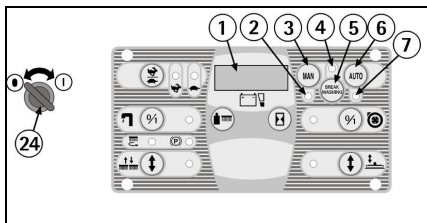

FORWARD AND BACKWARD MOVEMENT

It is always recommended to move and transport the machine in (BREAK WASHING) mode

To activate the movement of the machine proceed as follows:

1. Sit on the seat.
2. Turn the key switch (24) clockwise to switch on the machine.
3. Check the charge level of the batteries on the display (1).
4. Pressing the push button (5) the functioning of BREAK WASHING is chosen to carry out the transfer of the machine. In fact, in this mode the washing functions of the machine are not working and only the traction system functions. When the signal lamp (4) is on, then the machine is in BREAK WASHING mode.
5. Check through the signal lamp (15) that the parking brake is not on and release it if required (see under paragraph EMERGENCY-PARKING BRAKE).
6. Positioning the selector (28) forward, the forward drive is chosen, while positioning it back, the rear drive is selected.
7. Press the accelerator pedal placed on the right of the platform to start the machine.
8. Adjust the speed in forward drive by pressing the push button (21) to choose the slow one (maximum 3,6 km/h) or the fast one (maximum 5 km/h). The signal lamp (22) indicates

that the fast drive is selected, while signal lamp (23) indicates that the slow drive is selected.

9. When moving in reverse, an intermittent warning device is activated.

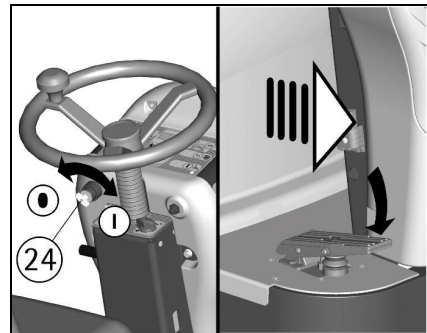
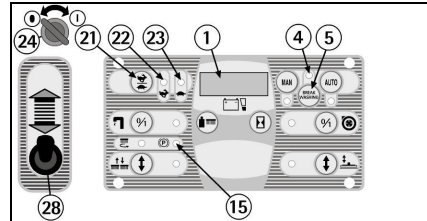

HORN

The machine is equipped with a horn which is activated by pressing the push button (1).

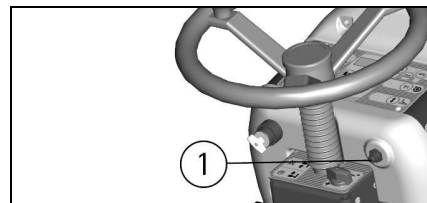

WORKING BRAKE

To stop the machine during normal working conditions, it is sufficient to release the accelerator pedal, because the machine has an electronic brake system. To restart, press the accelerator pedal again.

EMERGENCY BRAKE

In case of an emergency, press the brake pedal (1) placed on the left-hand side of the platform
To activate the parking brake press the brake pedal (1) and simultaneously move the lever downward (2) situated on the left side of the steering column.
On the instrument board the signal lamp (15) comes on which signals that the parking brake is on.
To release the parking brake press the brake pedal (1).

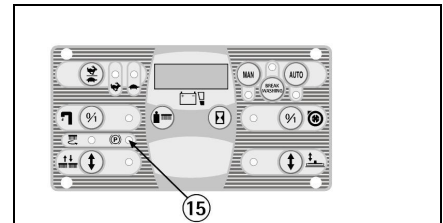
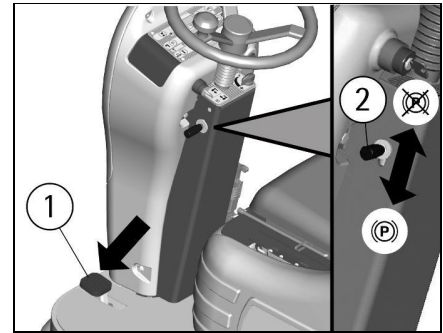

AUTOMATIC SQUEEGEE LIFTING WHEN GOING BACKWARDS

When reverse movement is selected the squeegee is automatically raised to the upper position. It will then lower again once the forward movement has been selected.

This happens both in automatic and in manual mode in order to protect the squeegee.

WORKING IN AUTOMATIC MODE

The automatic mode of operation is useful to simplify the operator's work.

1. Activate the machine (see under paragraph **STARTING THE MACHINE**).
2. Pressing the push button (6) the automatic (AUTO) mode function is selected. When the signal lamp (7) is on, then the machine is functioning in automatic (AUTO) mode.
3. Check that the knob of the solution valve (27) is in the position of optimum flow, depending on the type of floor and the type of dirt (see under the paragraph **FLOW ADJUSTMENT OF THE DETERGENT SOLUTION**).
4. Position the selector (28) forward to choose the forward drive.
5. Adjust the movement speed in forward with the push button (21) (see under paragraph "FORWARD AND BACKWARD MOVEMENT").
6. By pressing the accelerator pedal, the machine begins to move forward and in automatic mode pressing the accelerator pedal activates all the working functions. Automatically the squeegee goes down, the brushes begin to turn, the

solenoid valve opens to permit the detergent solution to flow down onto the brushes and the vacuum system is activated to recover the dirty water from the floor.

By positioning the selector (28) backwards the reverse drive is selected and by pressing the accelerator pedal the reverse drive starts, the squeegee lifts automatically and will then return to lower itself during the next forward movement.

If the accelerator pedal is released for more than 3 seconds, all the functions are automatically switched off and both the brushes stop and the squeegee is lifted. Pressing the pedal again, the machine starts to move and in automatic mode all the working functions are reactivated.

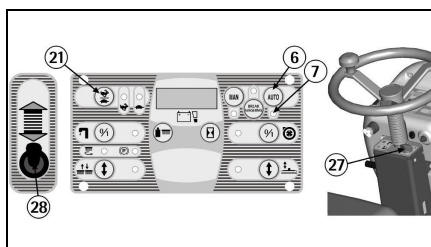

WORKING IN MANUAL MODE

The manual model is useful when, in specific cases, it is necessary to carry out only the washing with the brushes or only the drying of the floor.



ATTENTION:

The washing and drying functions, when they are not carried out simultaneously, represent an improper use of the machine (see under paragraph "GENERAL RULES OF SECURITY"). If they are carried out separately, it is necessary to prohibit un-authorized personnel from the cleaning areas and to signal areas of wet floors with suitable signs.

1. Activate the machine (see under paragraph "STARTING THE MACHINE").
2. Press the push button (3), manual (MAN) mode is chosen. When the signal lamp (2) is on, the machine is functioning in manual (MAN) mode.

TO CARRY OUT THE WASHING WITH ONLY THE BRUSHES:

1. Check that the knob of the solution valve (27) is in the position of optimum flow, depending on the type of floor and the type of dirt (see under the paragraph "FLOW ADJUSTMENT OF THE DETERGENT SOLUTION").
2. Press the push button (17) to lower the brushes. Once lowered, the brushes begin to turn. The signal lamp (16) indicates that the brushes base is lowering or lifting, while the signal lamp (18) signals that the brushes are turning.
3. Press the switch (19) to open the solenoid valve and permit the detergent solution to flow down onto the brushes. The signal lamp (20) will come on, to indicate that the solenoid valve is open.

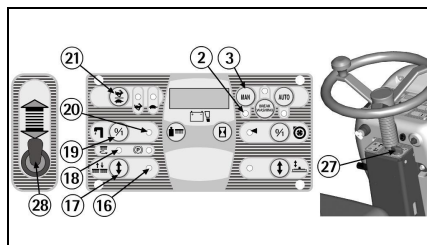

TO CARRY OUT THE FUNCTION OF ONLY DRYING:

1. Press the raise/lower squeegee button (11) to lower the squeegee. The signal lamp (12) indicates that the squeegee is lowering or lifting.
2. Press the vacuum motor switch (9) to start the vacuum system. The signal lamp (8) indicates that the machine is drying.

Position the selector (28) forward to choose the forward drive. Adjust the movement speed in forward with the push button (21) (see under paragraph "FORWARD AND BACKWARD MOVEMENT"). Pressing the accelerator pedal, the machine begins to proceed forward and to work according to the set functions.



ATTENTION:

In manual mode every function of the machine has to be activated or deactivated manually.

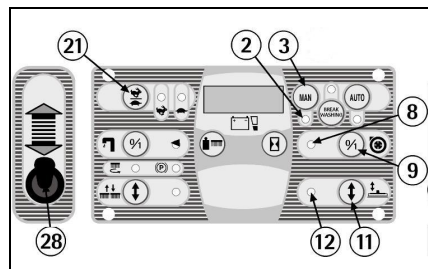

WORKING ADJUSTMENTS

In automatic mode as in manual mode, during the first metres check:

1. That the squeegee adjustment guarantees a perfect drying result (see under paragraph "SQUEEGEE ADJUSTMENT").
2. That the adjustment of the detergent solution flow is sufficient to wet the floor evenly avoiding the leakage of detergent from the splash guards (see under paragraph "FLOW ADJUSTMENT OF THE DETERGENT SOLUTION").
3. That the pressure of the brushes permit an efficient washing action in relation to the dirt and the speed (see under paragraph "ADJUSTMENT OF THE BRUSHES PRESSURE").

FLOW ADJUSTMENT OF THE DETERGENT SOLUTION

To adjust the detergent solution quantity that flows down onto the brushes it is necessary to adjust the solution valve knob (27) placed on the right of the steering column, rotate the knob counterclockwise to increase the flow and clockwise to reduce it up to shutting off the flow of solution.



BRUSH PRESSURE ADJUSTMENT

Using the knob (10) it is possible to adjust the brush pressure onto the floor in three pre-set pressure levels. The display (1) will indicate the pressure in kg that has been previously set by pressing the push button (14).

Adjustment is possible in both automatic and manual mode.

**ATTENTION:**

In order not to overload the brush motor, reduce the brush pressure going from smooth floors to rough ones (ex. concrete).

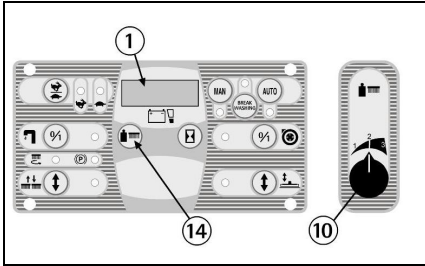
**ELECTRIC PROTECTION**

The machine is equipped with an electronic system of protection for all components that carry out functions of power or control. This device blocks the defective component and indicates on the display (1) the corresponding alarm from +AL01+ to %AL20+.

**ATTENTION:**

To restore the functioning of the component, turn the machine off and back on using the key switch. If the problem persists, please contact an authorized technical person.

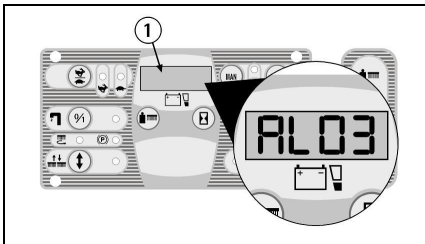
**OVERFLOW DEVICE**

To avoid serious damage to the vacuum motor, the machine is equipped with a mechanical float that intervenes when the recovery tank is full which closes the vacuum hose and stops the vacuum. When this happens, empty the recovery tank (see under paragraph %RECOVERY TANK EMPTYING AND CLEANING+).

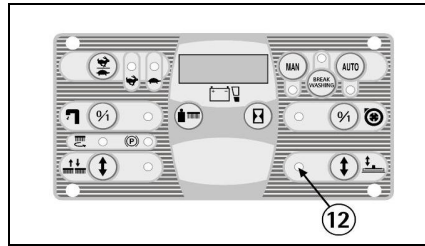
**STOPPING THE MACHINE AFTER CLEANING****IN AUTOMATIC OR MANUAL WORKING MODE:**

1. At the end of the washing cycle, pressing the push button (5), the function of BREAK WASHING is chosen. When the signal lamp (4) is on, then the machine is in BREAK WASHING mode. In this way the brushes lift automatically, the solenoid valve shuts down and it is possible to finish the drying operation.
2. When the accelerator pedal is released for more than 3 seconds, the squeegee raises itself and the vacuum switches off automatically.
3. After three seconds, the accelerator can be pressed again, if a machine's transfer has to be made (the transfer can be carried out also if the pedal is never lifted, in this case the squeegee gets lifted and the vacuum stops automatically after 15 seconds).
4. Turn the switch key counterclockwise to switch off the machine.
5. Insert the parking brake (see under paragraph %EMERGENCY-PARKING BRAKE+).

**ATTENTION:**

The mode (BREAK WASHING) is specific for the transfer at the end of the cleaning operation.

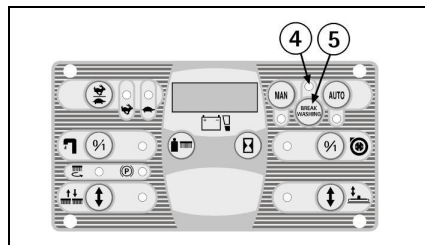

To start the cleaning operation again:
A. to start working in automatic mode (AUTO) press push button (6).
B. to start working in manual mode (MAN) press push button (3). All

functions have to be re-established manually.

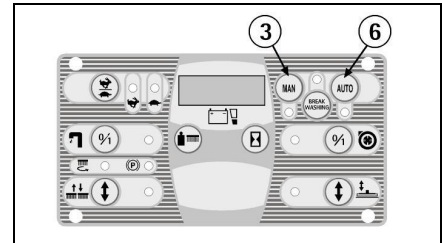
**DAILY MAINTENANCE****ATTENTION:**

The following maintenance and cleaning operations refer to those components that are in contact with liquids:

- Solution and recovery tanks
- Solution and recovery filters
- Squeegee including squeegees and hoses

• **Brushes**

The following operations must be carried out using gloves to protect from dangerous solutions.

EMPTYING AND CLEANING THE RECOVERY TANK

1. Hold the drain hose (1) placed in the rear part of the machine after having taken it off from its fixed position.
2. Take the plug off (2) the drain hose by pulling the lever (3) and empty the recovery tank into appropriate containers, in compliance with the respective rules of liquid disposal regulations.
3. Take off the vacuum cover (4) after rotating the blocking levers (5).
4. Take off the filter and the filter protection (6).
5. Rinse the inside of the tank with a water jet.
6. Reassemble all parts.

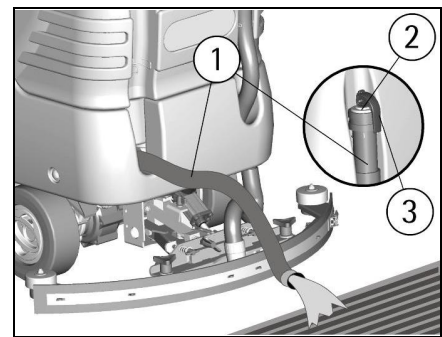

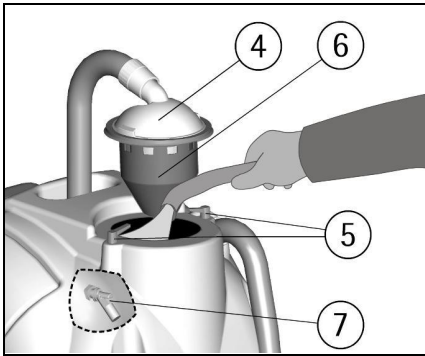

CLEANING THE VACUUM FILTER

1. Take off the vacuum cover (4) after rotating the blocking levers (5).
2. Take off the filter (8) and its filter protection (6).
3. Clean all parts with a water jet and especially the inside surfaces and the filter bottom.
4. Carry out cleaning operations carefully.
5. Reassemble all parts.

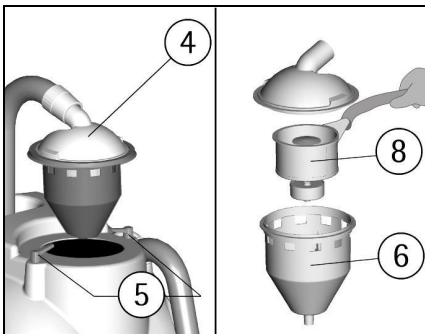

CLEANING THE BRUSHES

Disassemble the brushes and clean them with a water jet (for disassembling the brushes see under paragraph "DISASSEMBLING THE BRUSHES").

DISASSEMBLING THE BRUSHES

With the brushes base in the lifted position (see under paragraph "BRUSH ASSEMBLY"), rotate the brushes in order to release the button from the coupling spring until it becomes free and wash them with a water jet. The figure shows the rotating direction to release the brushes.



ATTENTION:

Disassembling the brushes with the electric supply on may cause injury.

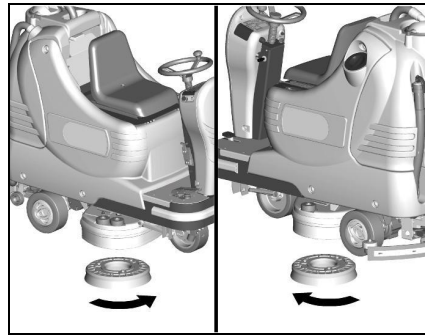

CLEANING THE SQUEEGEE

Keeping the squeegee clean guarantees the best drying result. To clean the squeegee it is necessary to:

1. Take off the squeegee hose (5) from the coupling.
2. Disassemble the squeegee (2) from its support (1) by loosening the knobs (4) counterclockwise and sliding the threaded parts in the appropriate slots up to their release.
3. Clean with care the internal part of the squeegee inlet eliminating any dirt.
4. Clean with care the squeegee rubbers.
5. Reassemble all parts paying attention to put the washers (3) into position, there are two for each knob, so that they are assembled one under and the other on each of the two slots present on the support.

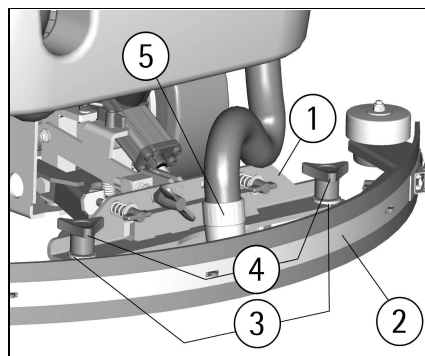

WEEKLY MAINTENANCE

REAR SQUEEGEE RUBBER CHECK

Check the squeegee rubber wear and eventually turn or replace it.

- For the replacement it is necessary to:
1. Lift the squeegee (see under paragraph "STOP OF THE MACHINE AFTER CLEANING OPERATION").
 2. Release the hook (1) of the rubber holder blade and take off the rubber.

3. Turn the rubber to a new side or replace it.

To reassemble the squeegee repeat inversely the operations mentioned above, inserting the rubber on the guides and blocking it with the rubber holder blade.

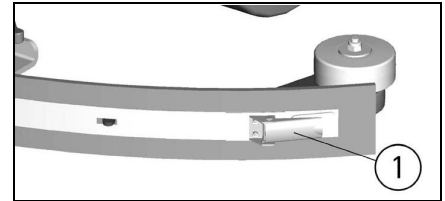

SQUEEGEE HOSE CLEANING

Weekly or in case of insufficient vacuum, it is necessary to check that the squeegee hose is not blocked. To clean it, proceed as follows:

1. Take off the hose (1) from the squeegee coupling.
2. Wash the inside of the hose with a water jet.
3. To reassemble the hose repeat in reverse the above-mentioned operations.

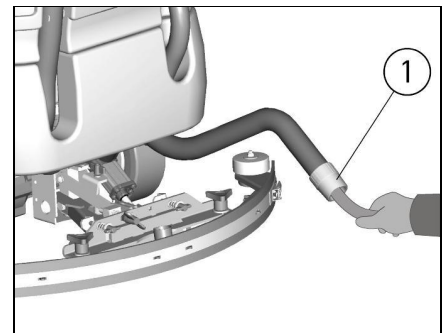

CLEANING THE SOLUTION TANK AND THE OUTER FILTER

1. Bring the machine to an appropriate area to drain the solution tank.
2. Unscrew the solution tank cap (1).
3. Unscrew the cap of the exhaust filter (2) and take off the filter. Be careful not to lose the cap's gasket.
4. Open the solution valve (see under paragraph "LOW ADJUSTMENT OF THE DETERGENT SOLUTION"), so that the detergent solution flows down into appropriate containers.
5. Rinse the solution tank and filter components with a water jet.

6. Reassemble all parts.

NOTE: if required it is possible to wash only the components of the outer solution filter by closing the solution valve adjustment (see under paragraph **LOW ADJUSTMENT OF THE DETERGENT SOLUTION**), so that the detergent solution remains in the solution tank.

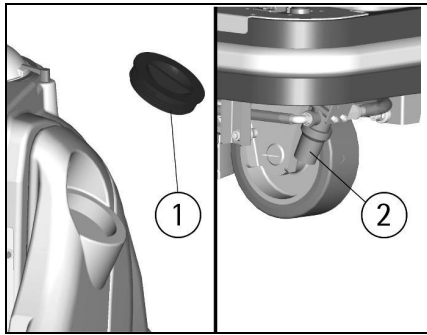

TWO-MONTHLY MAINTENANCE

FRONT SQUEEGEE RUBBER CHECK

Check the wear of the squeegee blade and replace when necessary. For replacement:

1. Take off the squeegee (see under paragraph **CLEANING THE SQUEEGEE**).
2. Unscrew the wing nuts in the front part of the squeegee.
3. Take off the squeegee holder blade.
4. Replace the front blade.
5. Reassemble all parts.

SIX-MONTHLY MAINTENANCE

SPLASH GUARD RUBBER CHECK

With the brushes assembled, the splash guards must touch the floor slightly. If they are worn, they have to be replaced. Just release the springs placed in the rear part of the brushes base group from the slots placed at the free extremities of the metal strips to take off the rubbers and to reinsert the new ones (see under paragraph **SPLASH GUARD ASSEMBLY**).

CLEANING THE INNER FILTER OF THE SOLUTION TANK

Empty the solution tank, remove the fitting (1) of the water outlet by taking off the two screws that fix it to the tank in the rear part of the machine. Clean the inside filtration part of the fitting.

Pour some water into the tank to clean it. Reassemble the fitting onto the solution tank.

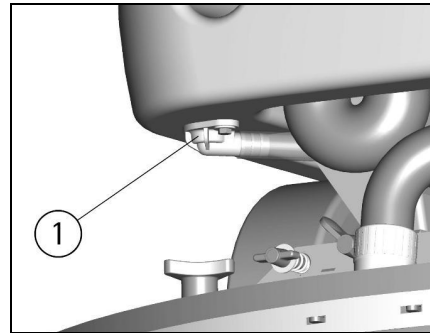

CHECKING THE BRAKES

Check the brake of both rear wheels. Should the braking be insufficient, please contact an authorized technical assistance.

TROUBLESHOOTING GUIDE



ATTENTION:

If when the key switch is positioned clockwise when switching the machine on and the display and other functions are not activated, it is necessary to check the batteries' connection to the machine (see under paragraph **CONNECTION BATTERIES' CONNECTION AND STARTING THE MACHINE**). If the problem persists, please contact the authorized technical assistance.

THE VACUUM MOTOR DOES NOT WORK

1. Verify that the key switch is positioned clockwise to switch on the machine. If the alarm signals it is necessary to switch the machine off and on again to restore the functionality.
2. Check the charge level of the batteries on the display (1).
3. Verify that the drying function is correctly activated. (see under paragraph **STARTING THE MACHINE**).
4. Check that the recovery tank is not full.
5. If, both in mode (MAN) and (AUTO), the signal lamp (8) is on but the vacuum system does not work, please contact the authorized technical assistance.

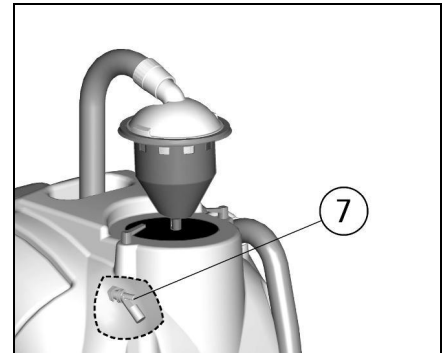
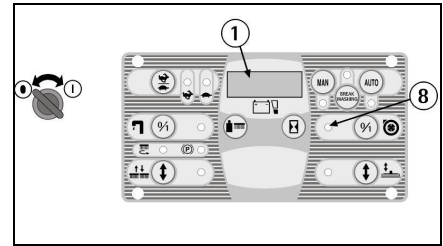

THE BRUSH MOTOR DOES NOT WORK

1. Verify that the key switch is positioned clockwise to switch on the machine. If the alarm signals it is necessary to switch the machine off and on again to restore the functionality.
2. Check the charge level of the batteries on the display (1).
3. Verify that the function of washing with the brushes has been correctly selected (see under paragraph **STARTING THE MACHINE**).
4. If, both in mode (MAN) and (AUTO), the signal lamp (18) is on but the brushes do not turn, please contact an authorized technical centre.

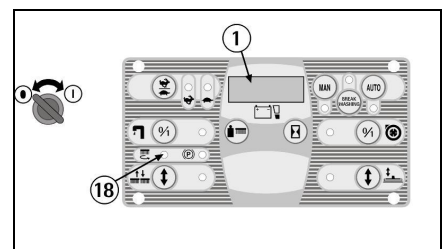

THE TRACTION MOTOR DOES NOT WORK

1. Sit on the seat.
2. Verify that the key switch is positioned clockwise to switch on the machine. If the alarm signals it is necessary to switch the machine off and on again to restore the functionality.
3. Check the charge level of the batteries on the display (1).

4. Check that the parking brake signal lamp (15) is not on and release it if necessary (see under paragraph **EMERGENCY-PARKING BRAKE**).
5. Press the accelerator pedal placed on the right side to start the machine. If the problem persists, please contact the authorized technical assistance.

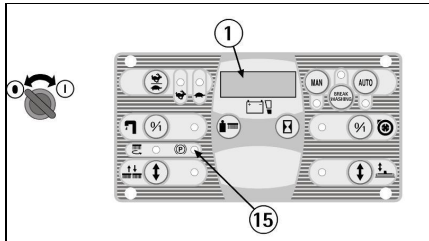

THE WATER DOES NOT COME DOWN ONTO THE BRUSHES OR IS INSUFFICIENT

1. Verify that the key switch is positioned clockwise to switch on the machine.
2. Check the charge level of the batteries on the display (1).
3. Verify that the function of washing with the brushes is correctly activated (see under paragraph **STARTING THE MACHINE**).
4. Check that the solution valve is open (see under paragraph **LOW ADJUSTMENT OF THE DETERGENT SOLUTION**).
5. If, both in (MAN) and (AUTO), mode the signal lamp (20) is on but the detergent solution does not come down onto the brushes, it is necessary to:
 - a. check the level of the liquid in the tank.
 - b. check that the solution filter is clean (see under paragraph **CLEANING THE SOLUTION TANK AND THE OUTER FILTER**).
 - c. check that the inner filter of the solution tank is clean (see under paragraph **CLEANING THE INNER FILTER OF THE SOLUTION TANK**).

If the problem persists, please contact the authorized technical assistance.

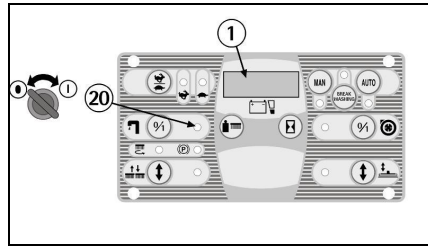

THE MACHINE DOES NOT CLEAN PROPERLY

1. The brushes do not have the suitable bristle dimension: contact an authorized technical centre.
2. The brushes have worn out bristles. Check the brush wear condition and replace if necessary (the brushes have to be replaced when the bristles have reached a height of about 1/2 + 15mm).

To replace the brushes, see instructions under paragraph **DISASSEMBLING THE BRUSHES** and **ASSEMBLING THE BRUSHES**.

3. The detergent solution is insufficient: open the solution valve more (see under paragraph **LOW ADJUSTMENT OF THE DETERGENT SOLUTION**).
4. Check that the liquid detergent is in the recommended percentage.
5. Increase the brush base pressure (see under paragraph **BRUSHES PRESSURE ADJUSTMENT**). Contact an authorized technical centre for advice.

THE SQUEEGEE DOES NOT DRY SUFFICIENTLY

1. Check that the vacuum function is on and that the recovery tank is not full.
2. Check that the squeegee blades are clean (see under paragraph **CLEANING THE SQUEEGEE**).
3. Check the adjustment of the height and the inclination of the squeegee (see under paragraph **SQUEEGEE ADJUSTMENT**).
4. Check that the vacuum and the squeegee hoses are correctly inserted in their proper seats on the recovery tank.

5. Clean the vacuum filter (see under paragraph **CLEANING THE VACUUM MOTOR**).
6. Clean the squeegee hose (see under paragraph **SQUEEGEE HOSE CLEANING**).
7. Replace the blades if worn out.

EXCESSIVE FOAM PRODUCTION

Check that low foam detergent has been used. Add small quantities of anti foam liquid into the recovery tank. Please be aware that more foam is produced the cleaner the floor. In this case please dilute detergent solution.

PROGRAMMED MAINTENANCE

INTERVAL	DAILY	20 HOURS *	200 HOURS *	1000 HOURS *
RECOVERY TANK CLEANING	•			
VACUUM FILTER CLEANING	•			
SOLUTION TANK FILTER CLEANING		•		
BRUSH CLEANING	•			
BRUSH DISASSEMBLY AND CLEANING	•			
SQUEEGEE CLEANING	•			
FRONT SQUEEGEE BLADE REPLACEMENT			•	
REAR SQUEEGEE BLADE REPLACEMENT		•		
SPLASH GUARD RUBBER REPLACEMENT				•
CHECK SQUEEGEE ADJUSTMENT		•		
SQUEEGEE HOSE CLEANING		•		
SOLUTION TANK CLEANING		•		
CHECK BATTERY ELECTROLYTE		•		
CHECK THE BRAKE				•
CHECK THE TRACTION MOTOR				•
CHECK THE BRUSH MOTOR				•
CHECK THE VACUUM MOTOR				•
CHECK THE BRUSH BASE			•	
SCREW TIGHTENING				•

* The hours refer to the ones indicated on the display (see under paragraph «HOUR METER»).

RECOMMENDED BRUSHES

Brushes must be chosen depending on floor type and dirt to be removed.

The material and bristle diameter are the elements that distinguish different types of brushes.

MATERIAL	CHARACTERISTICS
PPL (Polypropylene)	Good wear resistance. Maintains characteristics with hot water up to 50°C. It is not hygroscopic.
NYLON	Excellent wear resistance, even with hot water. It is hygroscopic.
TYNEX	Nylon bristles with grains of abrasive material. Use with caution in order not to mark the floor or ruin the polishing.
BRISTLES THICKNESS	Thicker bristles are more rigid and must be used on smooth floor or floor with small joints. On irregular floors with deep joints or relieves, it is recommended to use softer bristles which penetrate more easily and deeper. Please be aware that when brush bristles are worn out and therefore too small, they become rigid and unable to penetrate and clean deeper. This may also happen with thicker bristles creating brush vibration.
PAD HOLDER	It has anchor points which permit the blocking of the abrasive pad during work. The pad is recommended to clean smooth floors.

MACHINE	CODE	QUANTITY	DESCRIPTION	USE
BD26/22	48903020	2	Brush PPL 0,6 Ø 345	Normal floors.
	48903030	2	Brush PPL 0,9 Ø 345	Smooth floors with small joints and persistent dirt.
	48903040	2	Brush TYNEX Ø 345	Floors of resistant material and particularly dirty.
	48803030	2	Pad holder Ø 330 + center lock green	For pads of 14+, for smooth surfaces cleaning.